

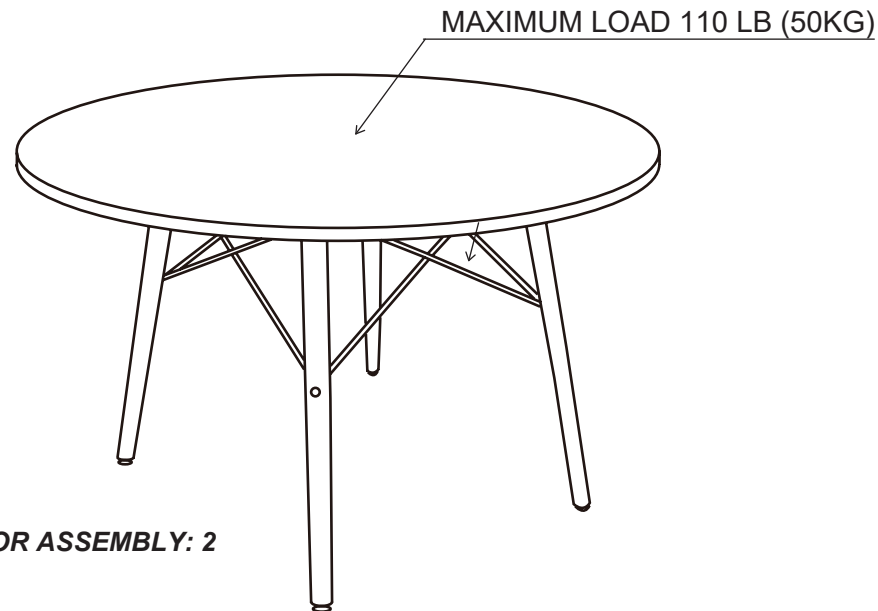

MAINSTAYS 42" ROUND MODERN DINING TABLE

STOCK # Z005.2318-MP

 **WARNING:**
ADULT ASSEMBLY REQUIRED



RECOMMENDED NUMBER OF PEOPLE FOR ASSEMBLY: 2
ESTIMATED ASSEMBLY TIME: 30 MIN

- CALL OUR TOLL FREE NUMBER **1-877-637-3590** FOR ASSISTANCE. WE ARE AVAILABLE TO ASSIST YOU MONDAY-FRIDAY FROM 9am-5pm EASTERN STANDARD TIME OR SEND US YOUR QUESTIONS TO asprod2015@gmail.com.
- ADDITIONAL PARTS ARE AVAILABLE FOR A FEE.
- THIS INSTRUCTION BOOKLET CONTAINS **IMPORTANT** SAFETY INFORMATION. PLEASE READ AND KEEP FOR FUTURE REFERENCE.
- DO NOT ALLOW CHILDREN TO CLIMB OR PLAY ON THE UNIT.
- CLEAN THE PRODUCT WITH YOUR FAVORITE FURNITURE POLISH AND A SOFT CLOTH.
- DO NOT USE HARSH CHEMICALS OR ABRASIVE CLEANERS.
- MOVE YOUR NEW FURNITURE CAREFULLY WITH TWO PEOPLE. NEVER PUSH OR DRAG THE UNIT.

FOR MISSING OR DAMAGED PARTS, PLEASE CALL 1-877-637-3590 BEFORE RETURNING THE PRODUCT TO STORE. PARTS WILL BE SHIPPED FREE OF CHARGE WITHIN 90 DAYS OF PURCHASE WITH PROOF OF PURCHASE. PLEASE CALL OUR TOLL FREE NUMBER OR E-MAIL TO asprod2015@gmail.com

FOR PROMPT, RELIABLE SERVICE, PLEASE HAVE YOUR ASSEMBLY MANUAL READY.

LOT NUMBER _____
DATE OF PURCHASE ____ _

Manufactured By: Saigon Furniture Co., Ltd.
Zhejiang, China
TEL: 1-877-637-3590 EMAIL: asprod2015@gmail.com



We are available to assist you Monday - Friday
from 9:00 am - 5:00 pm Eastern Standard Time.
1-877-637-3590

MAINSTAYS 42" ROUND MODERN DINING TABLE

STOCK # Z005.2318-MP



BEFORE STARTING

- Read and understand all the steps carefully before starting. Please follow the steps in the correct orders to avoid difficulties or damages to the parts during assembly. If each step is not followed in the correct order the assembly will be difficult and may result in damages.
- Work in a spacious area, preferably on a carpeted surface, near where the unit will be used.
- Make sure all the parts are included. Most boards are labeled with a removable sticker.

①

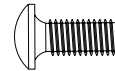

Bolt M6x20mm
Qty: 6 (2 for spare)

②



Bolt M6x45mm
Qty: 10 (2 for spare)

③

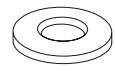

Gasket M6x18mm
Qty: 6 (2 for spare)

④



Nut
Qty: 10 (2 for spare)

⑤



Allen Wrench
Qty: 1

⑥

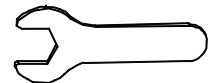

Wrench
Qty: 1



**DO NOT USE POWER TOOLS TO ASSEMBLE
YOUR FURNITURE. POWER TOOLS MAY
DAMAGE THE PARTS AND RESULT IN
DAMAGE.**

Manufactured By: Saigon Furniture Co.,Ltd.
Zhejiang , China
TEL: 1-877-637-3590 EMAIL: asprod2015@gmail.com



We are available to assist you Monday - Friday
from 9:00 am - 5:00 pm Eastern Standard Time.
1-877-637-3590

MAINSTAYS 42" ROUND MODERN DINING TABLE

STOCK # Z005.2318-MP

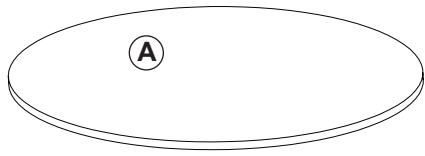
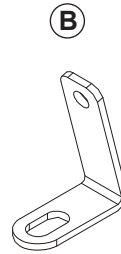
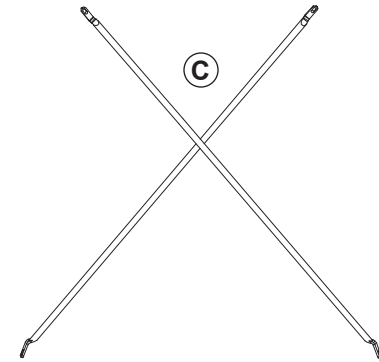

Table top
(Qty: 1)



Metal angel bracket
(Qty: 4)



Metal crosses
(Qty: 4)

D

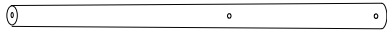

Wooden legs
(Qty: 4)

E

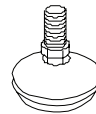

Bottom foot
(Qty: 4)

VERIFY THAT ALL PARTS ARE
LISTED BEFORE BEGINNING

1

Assemble the metal bottom foot E and the wooden leg D.

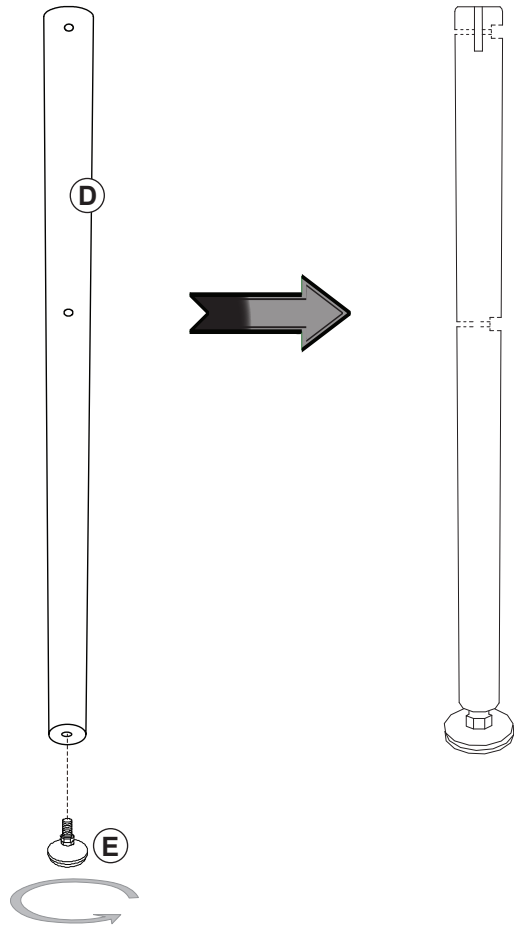

2

Install the metal angel bracket B on the back of the tabletop A with a bolts ① and a gasket ③. Place the angle bracket B in the right position as indicated in the drawing.

ATTENTION: TIGHTEN THE SCREW AT 50% ONLY.

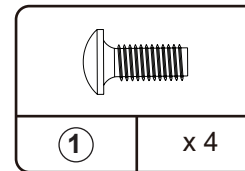
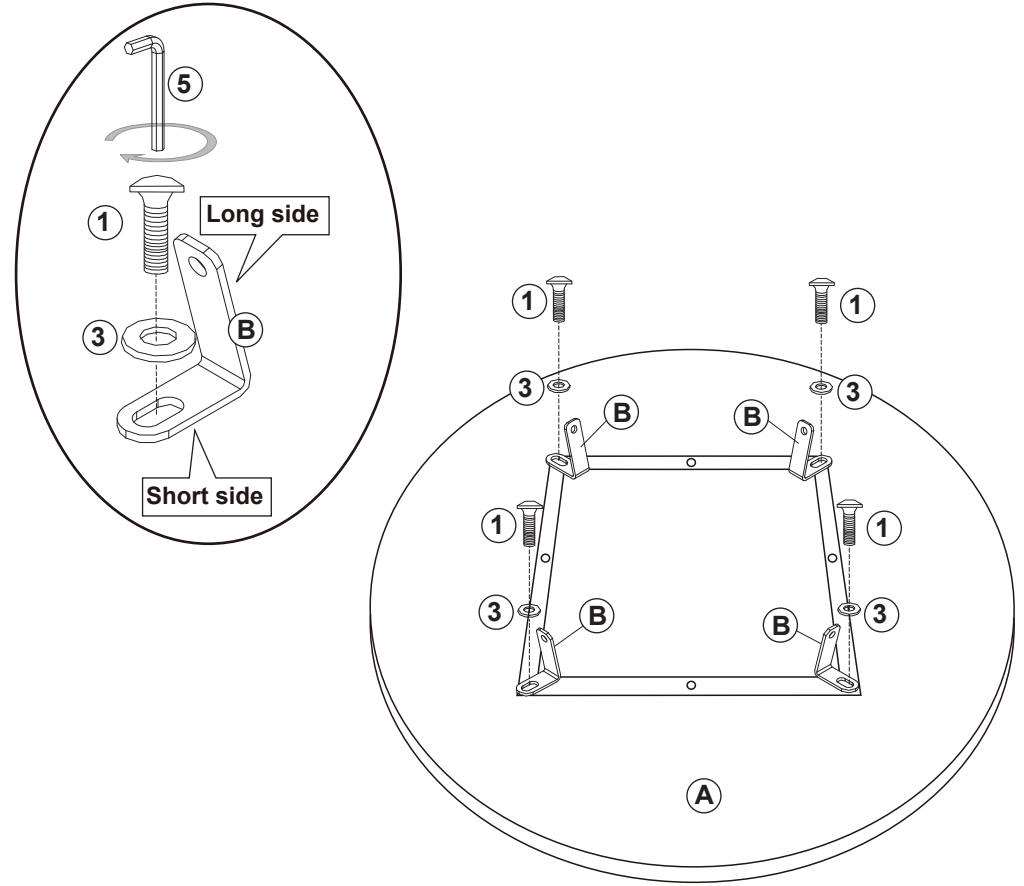

Bolt M6x20mm

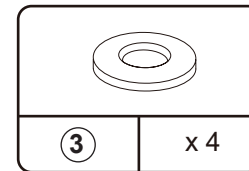

Gasket

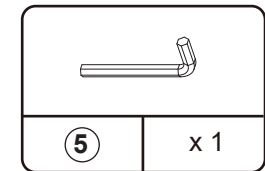

Gasket

3

Place the metal crosses C on the back of tabletop A in the right position as indicated in the drawing.

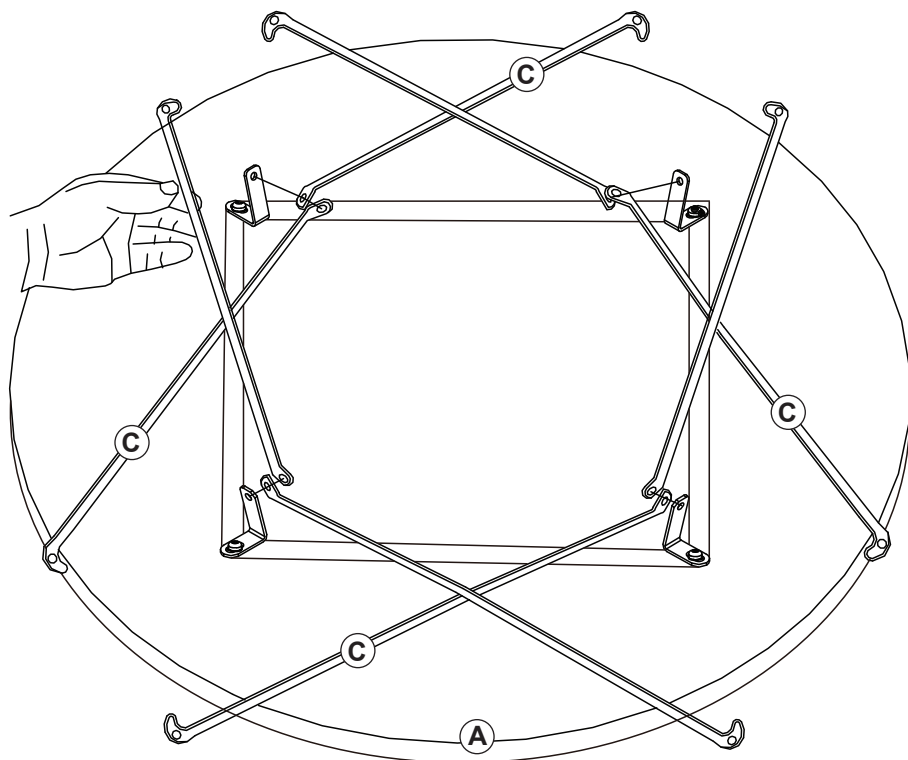

4

Install the wooden leg D from the top on the long edge of the angle bracket B, fix the bolts ② and nut ④ through the upper hole.

ATTENTION: KEEP OUTWARD THE BIGGER OUTCUT OF HOLE.
TIGHTEN THE SCREW AT 50% ONLY.

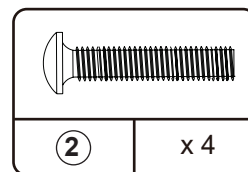
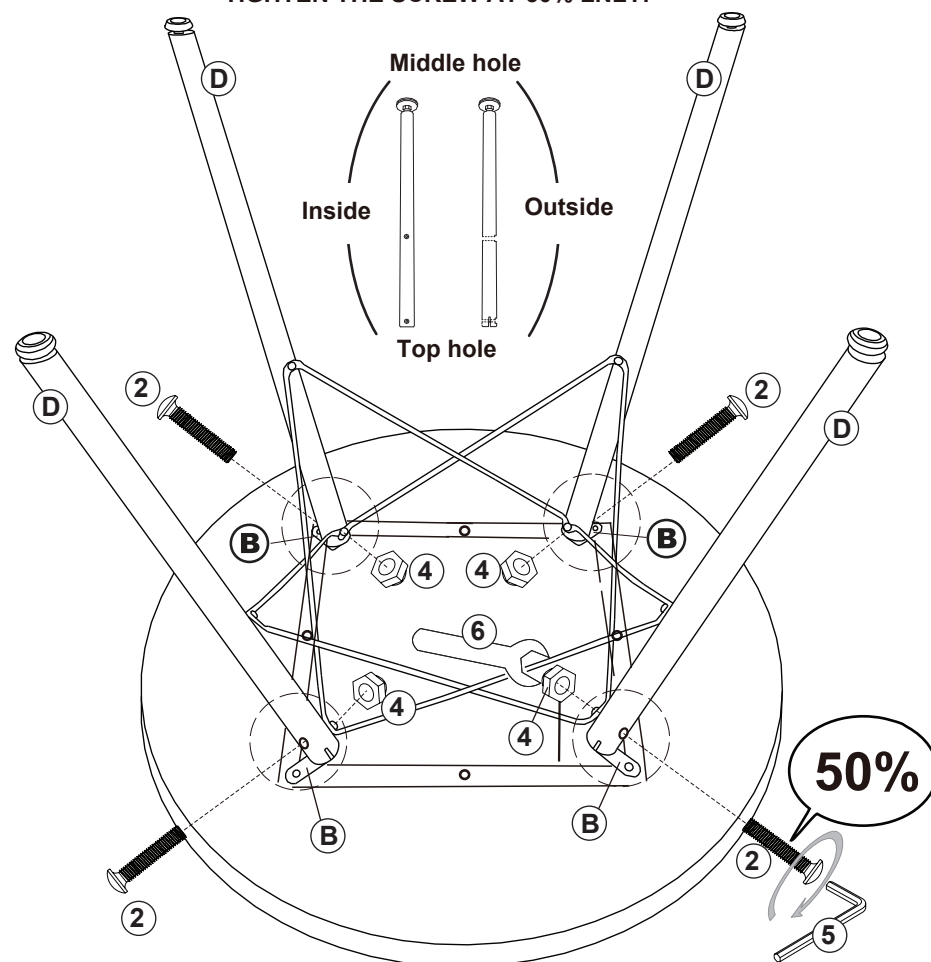

Bolt M6x45mm

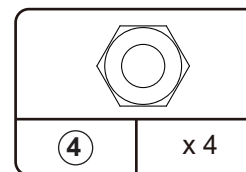

Nut

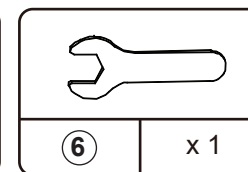

Wrench

5

Assemble the wooden legs D and the metal crosses C by fixing the bolts ② and nut ④ through the lower hole.

ATTENTION:
KEEP OUTWARD THE BIGGER
OUTCUT OF HOLE. TIGHTEN
THE SCREW AT 50% ONLY.

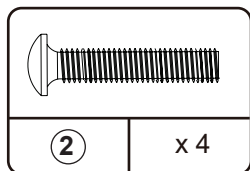
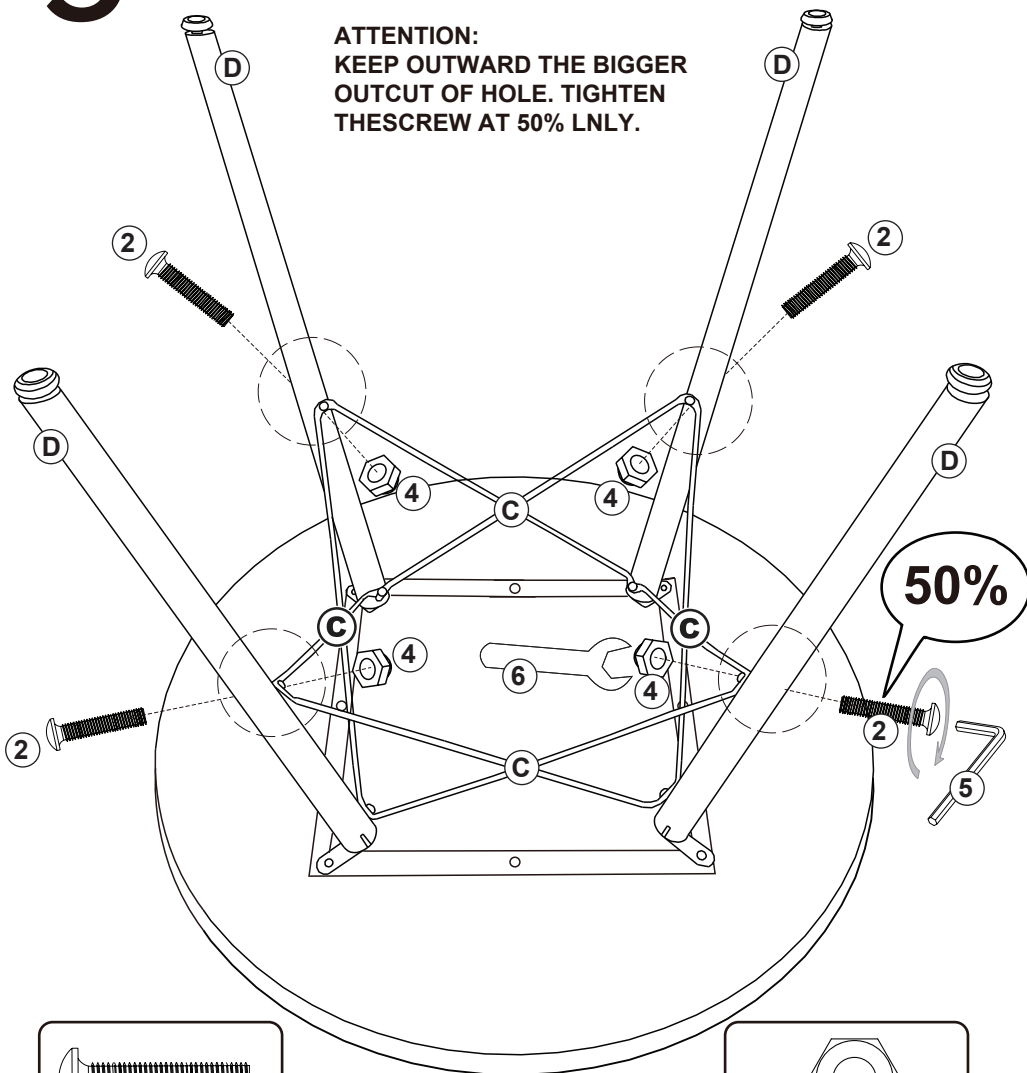

Bolt M6x45mm

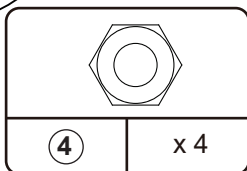

Nut

6

Fully tighten all bolts ① & ② and nuts installed in previous steps. Put the table on the floor. Adjust the metal bottom foot E to stabilize the table.

ATTENTION: 100% TIGHTEN ALL BOLTS

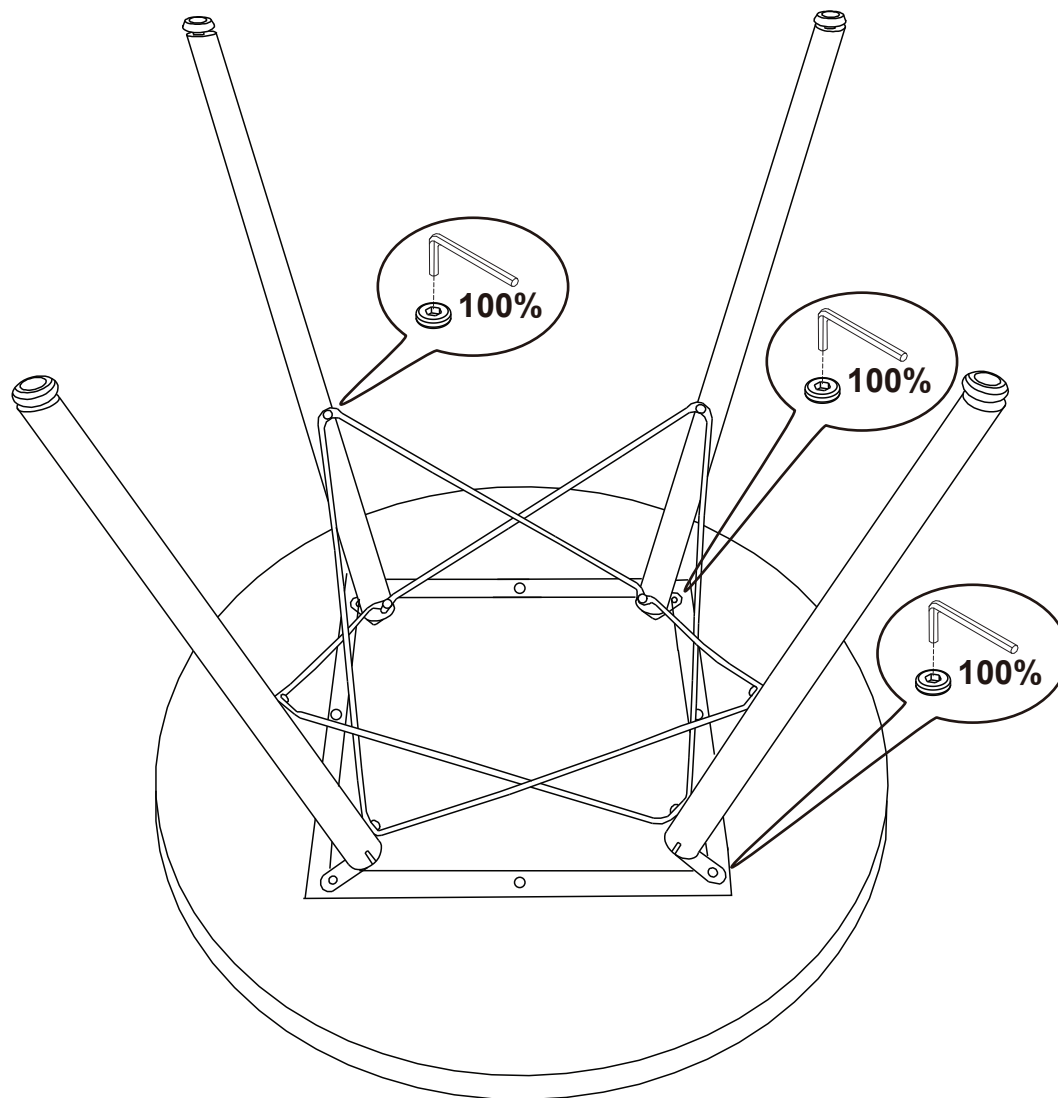

7

If you need to order parts please use the list below.
Please email defect photo and proof of purchase to asprod2015@gmail.com
Parts will be shipped free of charge within 90 days of purchase with proof of purchase.
Spare parts and services only support the purchase made from Walmart store or Walmart.com

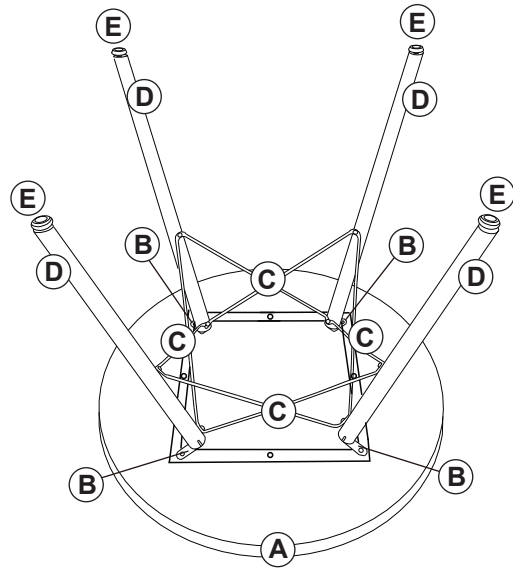

Parts

- A** Table top
- B** Metal angel bracket
- C** Metal crosses
- D** Wooden legs
- E** Bottom foot

Hardware

- 1** M6 x 20mm Bolt
- 2** M6 x 45mm Bolt
- 3** M6 Gasket
- 4** M6 Nut
- 5** Allen Wrench
- 6** Wrench



1

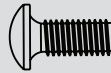

2



3

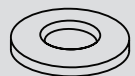

4

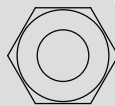

5



6

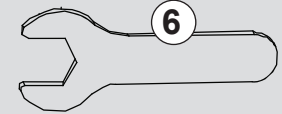



MAINSTAYS MESA DE COMEDOR REDONDA MODERNA DE 42"

STOCK # Z005.2318-MP

 **ADVERTENCIA:**
ASAMBLEA DE ADULTO REQUERIDO

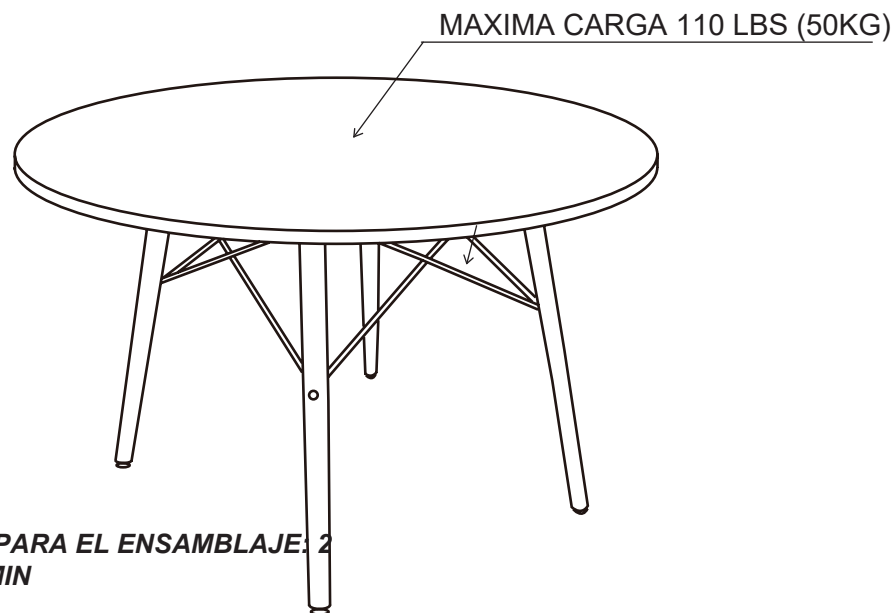

NÚMERO DE PERSONAS RECOMENDADO PARA EL ENSAMBLAJE: 2
TIEMPO ESTIMADO DE ENSAMBLAJE: 30 MIN

- LLAME A NUESTRO NÚMERO GRATUITO **1-877-637-3590** PARA OBTENER MÁS AYUDA.
- PIEZAS ADICIONALES ESTÁN DISPONIBLES POR UNA TARIFA.
- ESTE MANUAL DE INSTRUCCIÓN CONTIENE INFORMACIÓN **IMPORTANTE** DE SEGURIDAD. POR FAVOR DE LEER Y GUARDAR PARA FUTURAS REFERENCIAS.
- NO DEJAR A LOS NIÑOS SUBIR O JUGAR SOBRE LA UNIDAD.
- LIMPIAR EL PRODUCTO CON TU PULIDOR FAVORITE DE MUEBLE Y UN TRAPO BLANDO.
- NO USAR QUÍMICOS FUERTES O PRODUCTO DE LIMPIEZA ABRASIVO.
- MUEVA SUS NUEVOS MUEBLES CUIDADOSAMENTE CON DOS PERSONAS, NUNCA EMPUJE O ARRASTRE LA UNIDAD.

NO DEVOLVER EL PRODUCTO A LA TIENDA.
TIENDAS INDIVIDUALES NO RESERVAN PIEZAS.
PARA PIEZAS PERDIDAS O DAÑADAS LLAME AL
1-877-637-3590 O EMAIL A asprod2015@gmail.com
PARTES SERÁN ENVIADOS DE FORMA GRATUITA.

PARA UN SERVICIO RÁPIDO Y CONFIABLE, POR
FAVOR DE TENER A MANO EL MANUAL DE
ENSAMBLAJE.

NUMERO DE PARTIDA _____
FECHA DE COMPRA ____/____/____

Fabricante: Saigon Furniture Co.,Ltd.
Zhejiang , China

TEL: 1-877-637-3590 EMAIL: asprod2015@gmail.com



Estamos disponibles para ayudarlo de Lunes -
Voermes de 9:00 am - 5:00 pm Hora de la Zona Este.
1-877-637-3590

MAINSTAYS MESA DE COMEDOR REDONDA MODERNA DE 42"

STOCK # Z005.2318-MP



ANTES DE COMENZAR

- Leer y entender todos los pasos cuidadosamente antes de comenzar. si no se sigue cada paso en el orden correcto, el montaje será difícil y puede ocasionar daños.
- Trabajar en una zona amplia, mejor sobre la alfombra, cerca del sitio donde la unidad se utiliza.
- Asegurarse de que todas las piezas estén incluidos. La mayoría de los tableros están etiquetados con una pegatina removible.

①

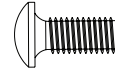

Tornillo De M6x20mm
Cantidad: 6 (2 de repuesto)

②



Tornillo De M6x45mm
Cantidad: 10 (2 de repuesto)

③

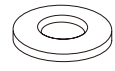

Rondana plana
Cantidad: 6 (2 de repuesto)

④



Tuerca
Cantidad: 10 (2 de repuesto)

⑤



Llave Allen
Qty: 1

⑥



Llave Inglesa
Qty: 1



**NO UTILICE HERRAMIENTAS ELÉCTRICAS
PARA MONTAR SUS MUEBLES.
HERRAMIENTAS ELÉCTRICAS PUEDEN
DAÑAR LAS PIEZAS Y PROVOCAR DAÑOS.**

Fabricante: Saigon Furniture Co.,Ltd.
Zhejiang , China

TEL: 1-877-637-3590 EMAIL: asprod2015@gmail.com



Estamos disponibles para ayudarlo de Lunes -
Voermes de 9:00 am - 5:00 pm Hora de la Zona Este.
1-877-637-3590

MAINSTAYS MESA DE COMEDOR REDONDA MODERNA DE 42"

STOCK # Z005.2318-MP

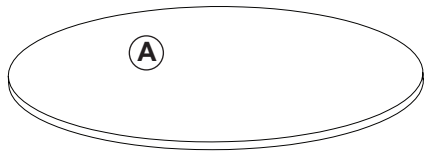

Mesa
(Cantidad: 1)

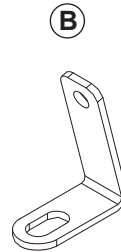

Soporte de metal
(Cantidad: 4)

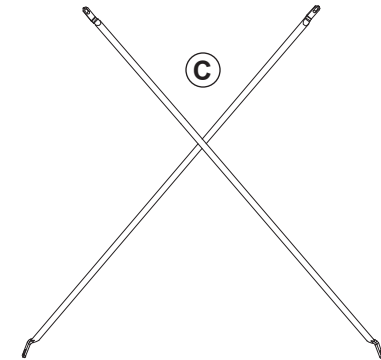

Cruces de metal
(Cantidad: 4)

D

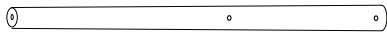

Patas de madera
(Cantidad: 4)

E

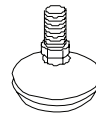

Pies
(Cantidad: 4)

Fabricante: Saigon Furniture Co.,Ltd.
Zhejiang , China

TEL: 1-877-637-3590 EMAIL: asprod2015@gmail.com

1

Monte los pies cromados E en la pata de madera D como se muestra.

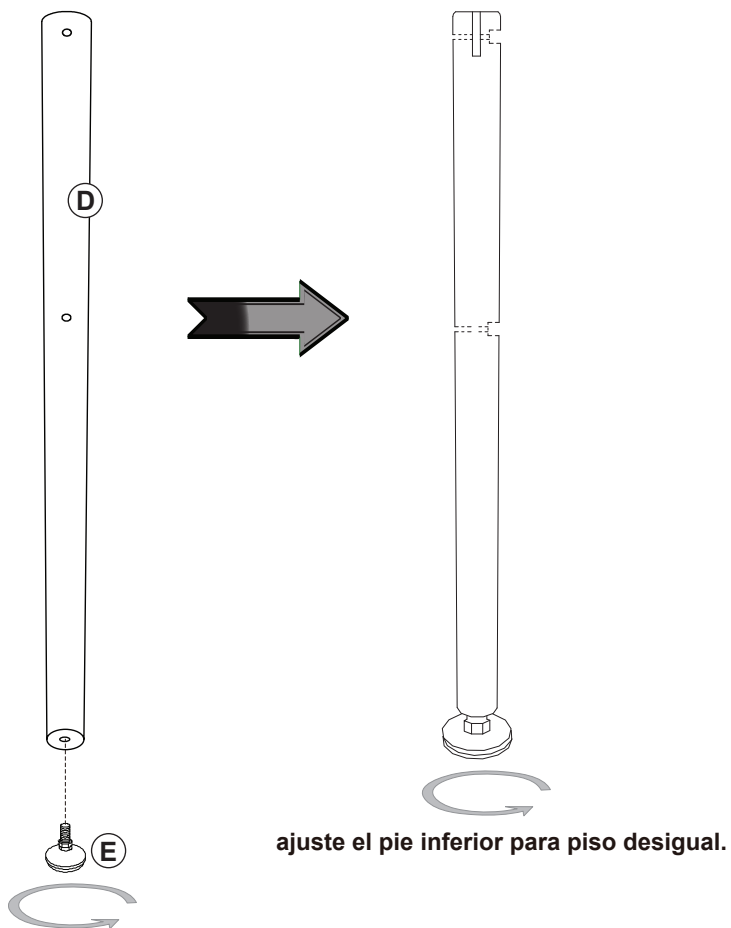

2

Use el tornillo ① y la rondana plana ③ con la llave allen ⑤ para ensamblar el soporte de metal B en la parte interior de la mesa. Por favor asegure se de que lado largo del soporte de metal B se una a la mesa panel inferior como se muestra.

Atención: 50% de montaje solo para torillos de este paso.

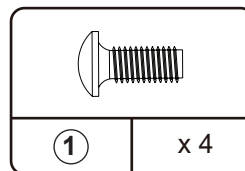
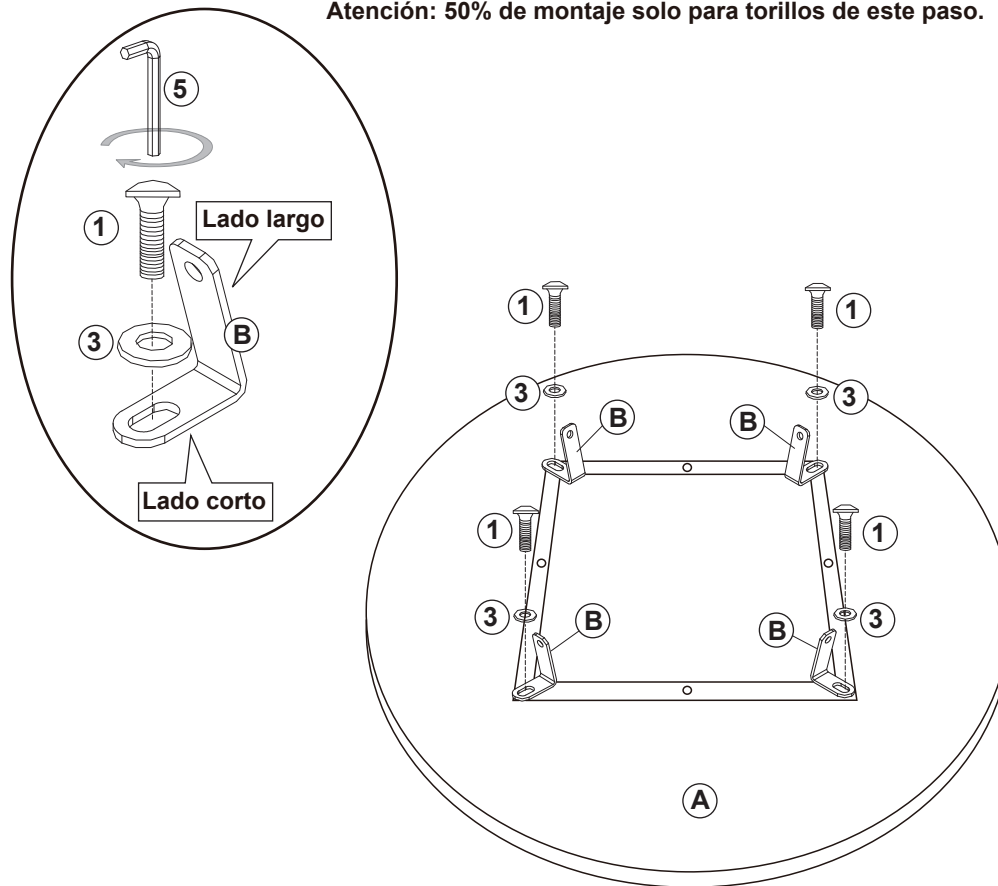

Tornillo De
M6x20mm

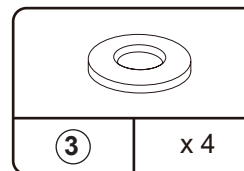

Rondana plana

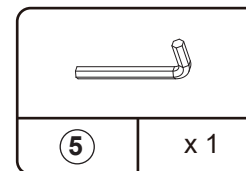

Llave Allen

3

Coloque una cruz de metal "x" C en el panel de la mesa y asegúrese de que cada pata de cruz metálica C esté colocada en la posición y dirección corrección correctas como se muestra.

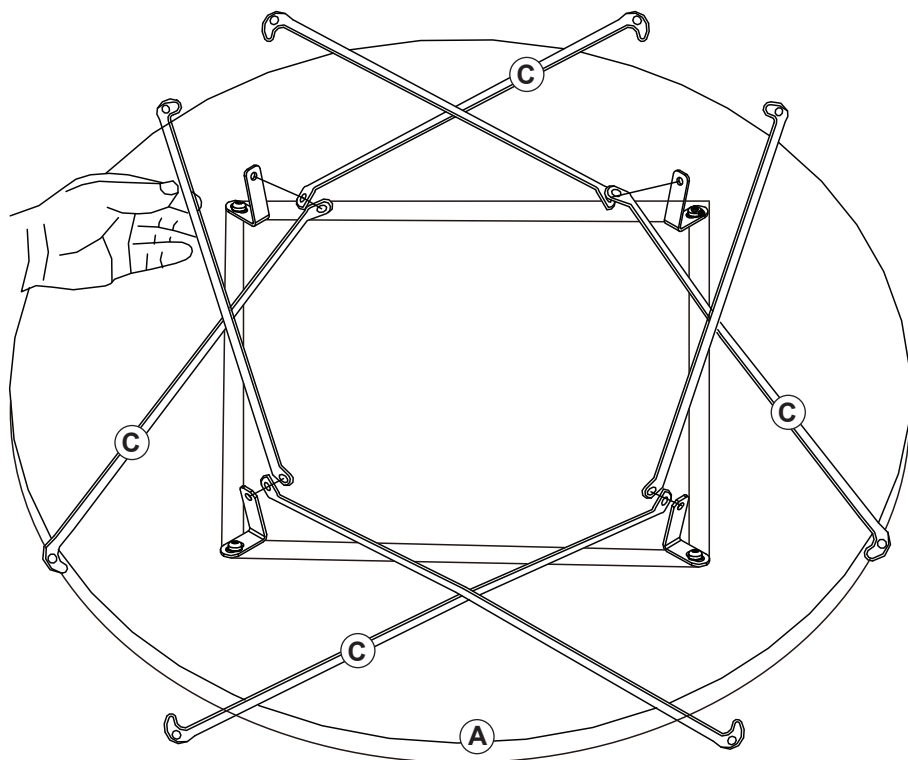

4

Inserte la pata de madera D extremo superior en lado largo del soporte metal B y use el tornillo (2) y la tuerca (4) del "orificio superior" de la pata de madera D con la llave allen (5) y la llave inglesa abierta (6) para fijar la pata como se muestra.

ATENCIÓN:
50% DE MONTAJE
SOLO PARA TORILLOS
DE ESTE PASO.

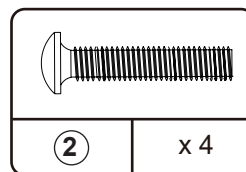
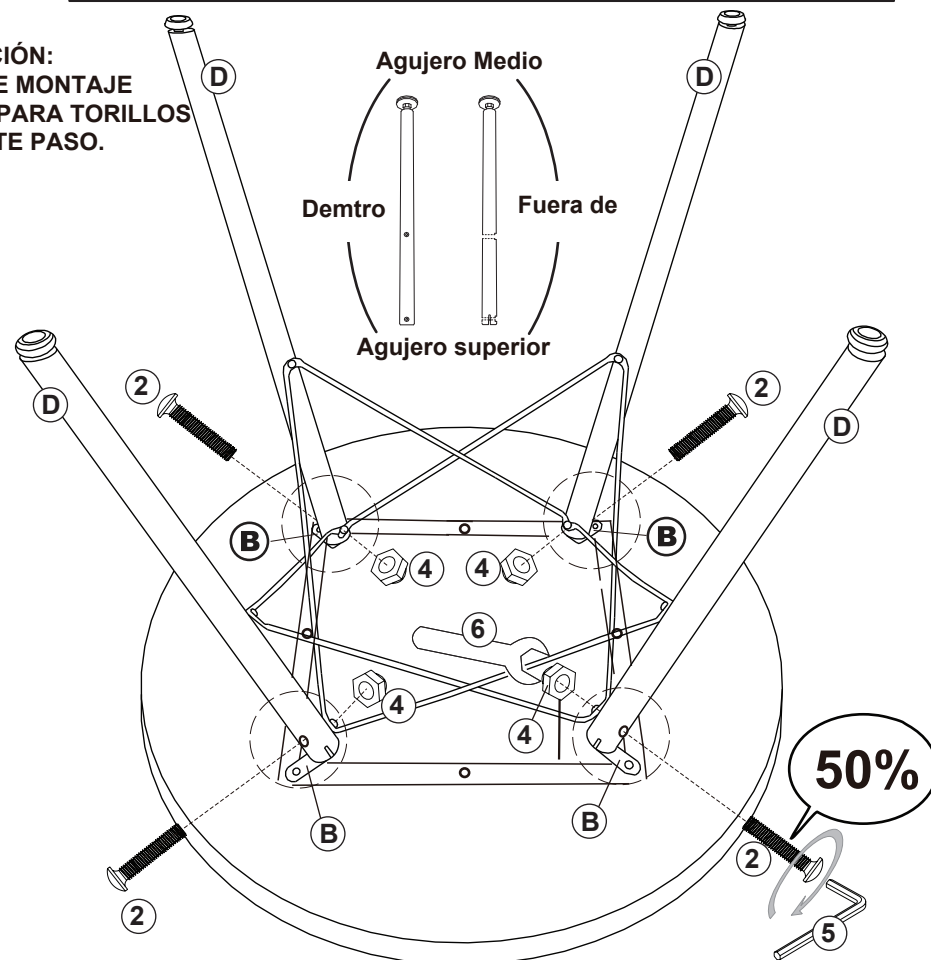

Tornillo De
M6x45mm

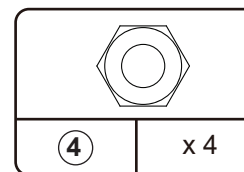

Tuerca

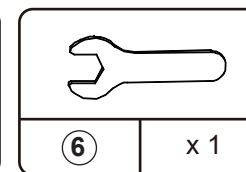

Llave Inglesa

5

Use el tornillo ② y la tuerca ④ desde el Agujero medio de pata de madera D con llave allen ⑤ y llave inglesa abierta ⑥ para ensamblar la pata de madera D y la cruz de metal C juntos.

ATENCIÓN:
50% DE MONTAJE SOLO PARA TORILLOS DE ESTE PASO.

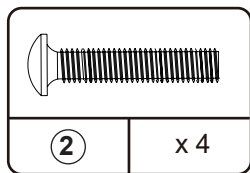
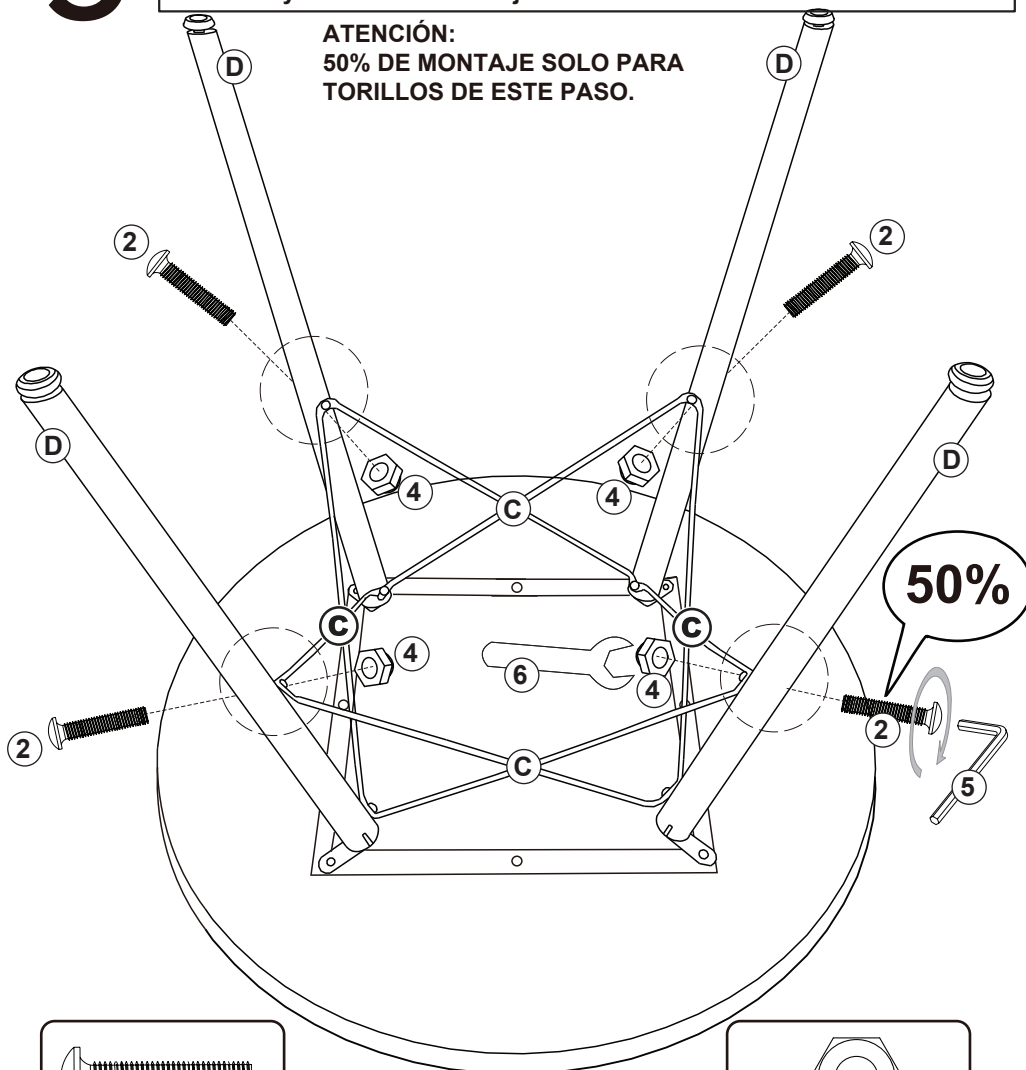

Tornillo De
M6x45mm

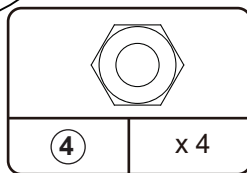

Tuerca

6

Apriete por completo al 100% todos los tornillos ① ② y tuercas ④ del paso B, Paso D y paso E y luego ponga la mesa en el piso como se muestra y ajuste los pies de cromo E para asegurarse de que las cuatro patas están equilibradas. Felicidades!
EL montaje de la mesa ha terminado!

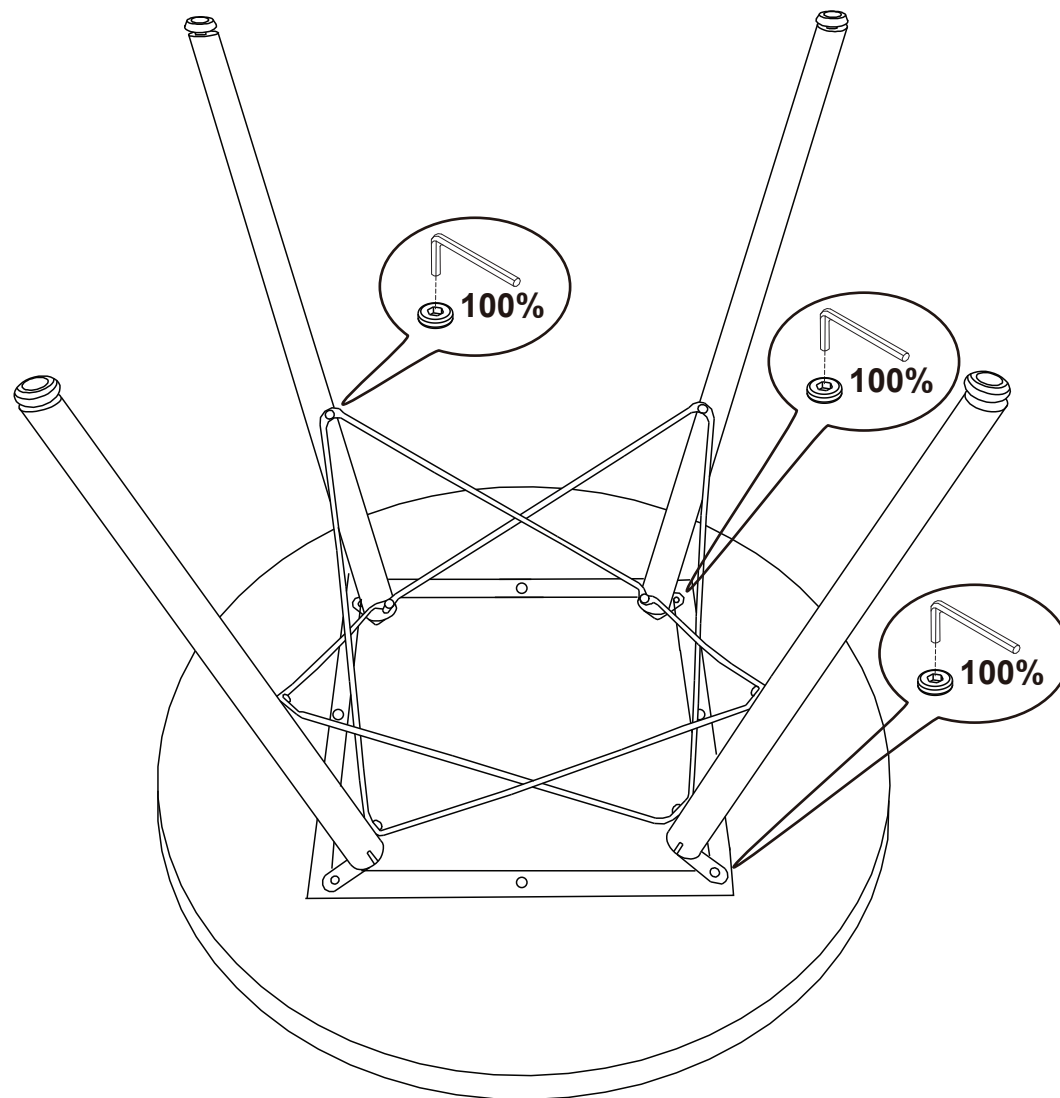

7

Si requiere pedir una parte por favor use la lista de abajo.
por favor envíe la foto de los defectos y la prueba de compra a asprod2018@gmail.com.
Allí puede incurrirse en costos para las partes y de la carga si no hay comprobante de compra y después de los 90 días de la compra de la Walmart supermercado o Walmart.com

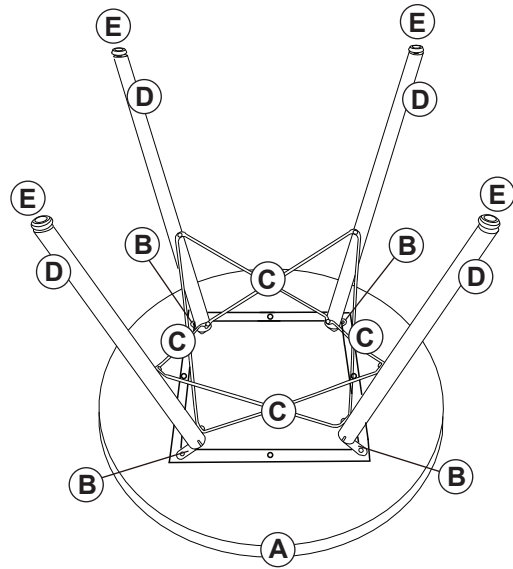

Parts

- A** Mesa
- B** Soporte de metal
- C** Cruces de metal
- D** Patas de madera
- E** Pies

Hardware

- 1** M6 x 20mm Tornillo De
- 2** M6 x 45mm Tornillo De
- 3** M6 Rondana plana
- 4** M6 Tuerca
- 5** Llave Allen
- 6** Llave Inglesa



1

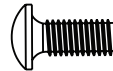

2



3

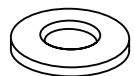

4

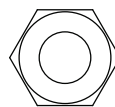

5



6

